



Rollerdor

THE ROLLER GARAGE DOOR SPECIALISTS

RD10X2ELL Control Box

Installation Guide for Roller Garage Doors

Edition 2024/1





1. INSTALLING RECEIVER BOX

(SAFETY EDGE)

- 1 Remove all 4 screws from cover (**fig.1**) to reveal control board inside (**fig.2**).
- 2 Place the Receiver box on the wall with the cable pointing downwards at a comfortable height to operate the push buttons, but out of the easy reach of children. Between 1500mm up from the floor and 300mm down from the roof/ ceiling is recommended, mark the 4 fixings, drill and secure the unit to the wall.
- 3 If you have a safety brake with a cable then run the two core cable from the safety brake end across to the same end as the receiver box, making sure to securely fix the cable out of the way of the working mechanism.
- 4 The Glands at the bottom are for the cables to be inserted, (1) motor wire (2) power wire (3) safety brake if supplied.
- 5 Wiring as follows (**fig.3, 4 & 5**):



fig.1

- Terminal 1 – Earth Motor Wire
- Terminal 2 – Earth Power Wire
- Terminal 3 – Power Brown Live Wire
- Terminal 4 – Power Blue Neutral Wire
- Terminal 5 – Motor Open Wire (left hand motor Black / right hand motor Brown)
- Terminal 6 – Motor Blue Neutral Wire
- Terminal 7 – Motor Close wire (left hand motor Brown / right hand motor Black)
- Terminal 16 – Safety Edge Brown Wire
- Terminal 17 – Safety Edge Green Wire
- Terminal 18 – Safety Edge White Wire

Safety Brake (fig.5 & 6):

Terminal 21 - Safety Brake = Blue Safety Brake Wire / No safety Brake = Link cable to Terminal 22.

Terminal 22 - Safety Brake = Brown Safety Brake Wire / No Safety Brake = Link wire to Terminal 21.



fig.2

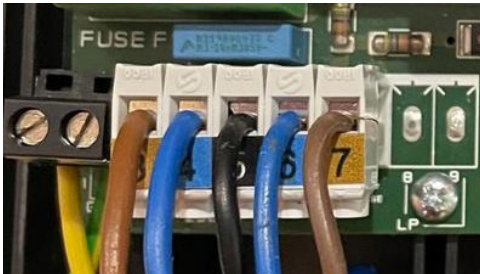

fig.4 Left Hand Motor

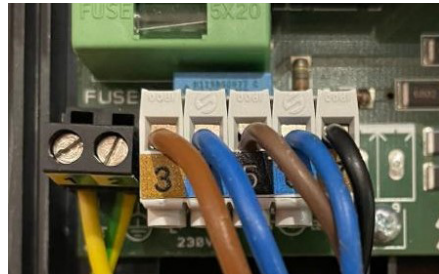

fig.3 Right Hand Motor

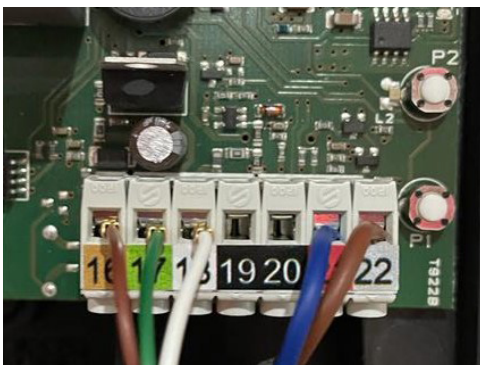

fig.5 Safety Brake

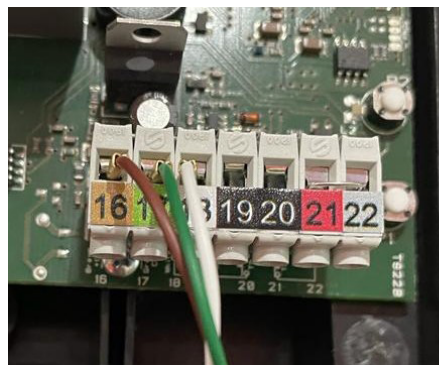
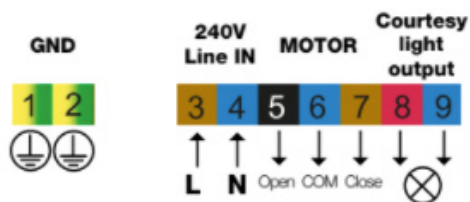

fig.6 No Safety Brake

2. ELECTRICAL CONNECTIONS

High voltage terminals



1	Motor Ground
2	240V- Power supply - Ground
3	240V- Power supply IN - LIVE
4	240V- Power supply IN - NEUTRAL
5	Motor - OPEN
6	Motor - COMMON
7	Motor - CLOSE
8	240V- COURTESY LIGHT (300W max. lamp)
9	

Low voltage terminals

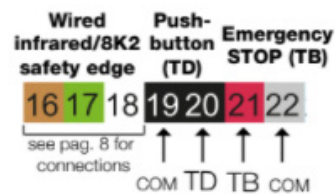

16	Infrared/8K2 safety edge input (brown)
17	Infrared/8K2 safety edge input (green)
18	Infrared/8K2 safety edge input (white)
19	Push-button common (COM)
20	Push-button (step-by-step, N.O.)
21	Emergency STOP push-button (N.C.)
22	Emergency STOP push-button common



3. SETTING UP WIRELESS SAFETY EDGE KIT

(OPTICAL EDGE)

CHECKING BASE RAIL UNIT

- 1 Your base rail unit is already installed on the last slat of your curtain the same side as the power. it is a small black unit, undo all 3 screws and remove the lid (fig.7).
- 2 Check GREEN LED is on, wires are secure and are wired follows: Both banks of terminals from outside to in are Brown - White - Green (fig.8).



fig.7

CHECKING CONTROL BOX

- 1 Control box Dip Switches: check dip switches on main board (fig.9) dip switch number 1 should be on and number 2 off.



fig.8

LIMITS

The control box is supplied in Hold to Run operation for open and close, this is signified by the flashing LED. If the limits of the motor have not been set then please set them now using the P1 (UP) & P2 (Down) buttons (fig.9). When completed you will need to take the unit out of Hold to Run by pressing both P1 & P2 buttons 3 times and on the third press hold until you hear a single beep (fig.10) and the LED stops flashing.

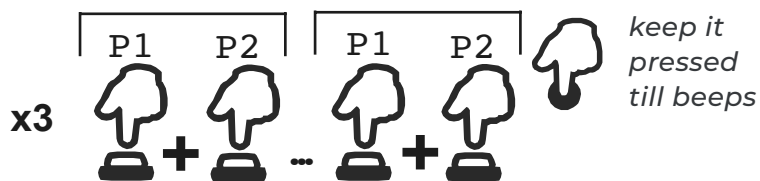

Press together P1 and P2 for 3 times and keep them pressed till beeps

fig.10

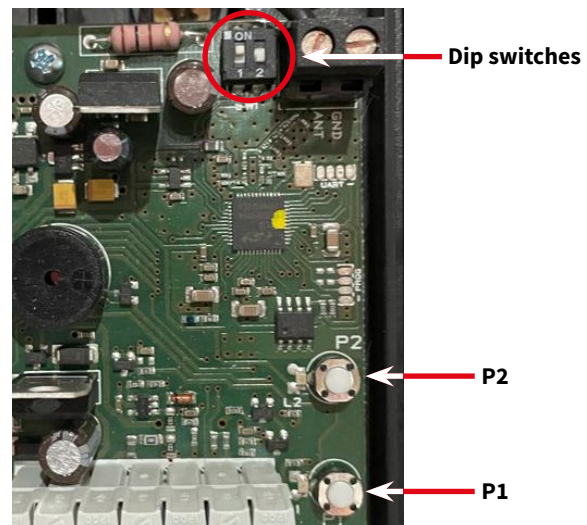

fig.9

PROGRAMMING TRANSMITTER'S

Step 1 - In order to add handsets the unit needs to be placed into programming mode, to do this press and hold both P1 & P2 buttons for 5 seconds and you will here 1 beep and the LED will light up (**fig.11**).

Programming Transmitters 2 Channel (**fig.12**):

- 1 Press P2 button two times, on last press HOLD causing the buzzer to emit a continuous sound.
- 2 Whilst P2 is still pressed, press the top button on the transmitter, you will hear a faster beeping sound.

Follow Step 1 first - Deleting ALL transmitters (**fig.13**):

- 1 Press P1 5 times and on last press HOLD for at least 10 seconds, buzzer emits a rapid beeping sound.
- 2 Once the sound becomes continuous release the P1 button.

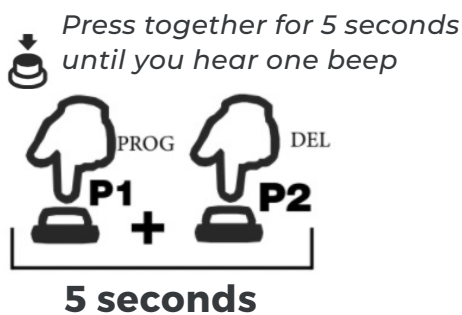

fig.11

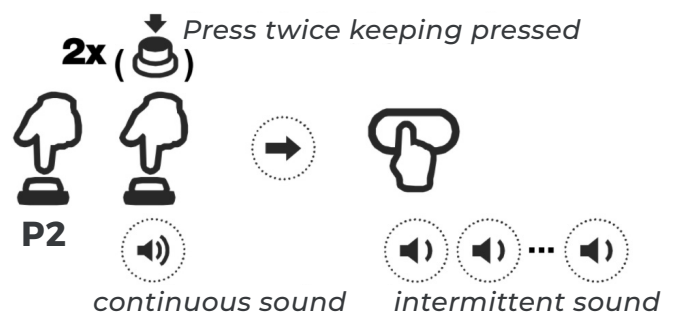

fig.12

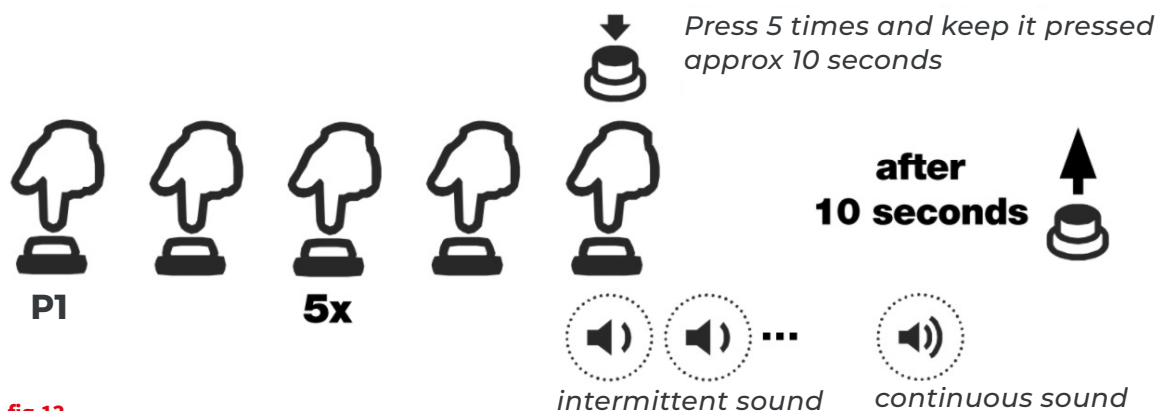

fig.13



WIRELESS KEY PAD

INSTALLATION

- 1 Undo and remove the small screw at the bottom and lift off the front cover.
- 2 Using the back-plate as a template, mark the positions of two suitable fixing holes onto the wall then secure the back-plate to the wall using the plugs and fixing screws provided.
- 3 Install the 9v alkaline battery that has been supplied then once set up and programming is completed push the keypad onto the back-plate and secure in place with the screw.

PAIRING USING ACCESS CODE

- 1 The keypad is supplied with a factory access code number "12345".
- 2 To pair keypad to receiver box, press and hold the P1 and P2 buttons for approximately 5 seconds until you hear a beep. Press and release the P2 button then press and hold the P2 button so that the box emits a continuous beep. Whilst holding the P2 button, enter the access code (12345) on the keypad then firmly press and release the number 1 on the keypad. The continuous beep will change to a faster beep which indicates that you can release all buttons and that the keypad is now programmed.

CHANGING ACCESS CODE

For security reasons it is essential that the access code number is changed to another 5 digit number these numbers can be in any combination of numbers 0-9, excluding A and B.

To change access code follow this sequence: Enter access code "12345", press M1 button (white button on the back of the keypad) a beep will be emitted, enter your new 5 digit code, within 1 second enter this same code again, when you hear a continuous beep for approx. 2 seconds this confirms the code has been changed.

OPERATION

Enter your individual 5 digit code each number will emit a short beep to signify it has been registered and the final number will give a longer beep to say full code has been entered, Press either number 1 to open or number 3 to close.

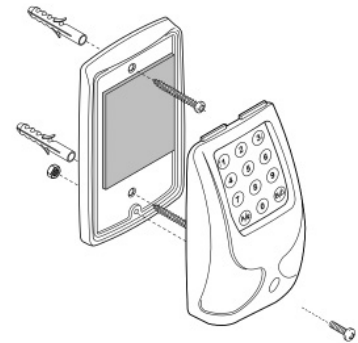
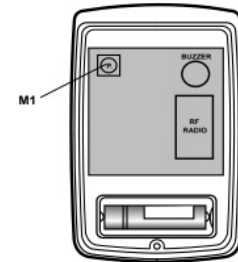
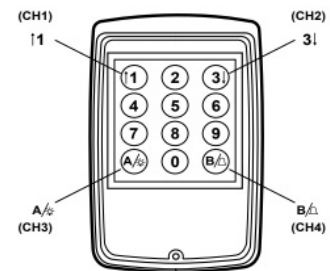
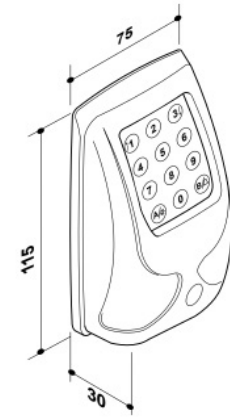

SAFETY EDGE EXCLUSION ZONE

- The curtain is supplied with stops at each end to stop an uneven floor having an effect (fig.14) but if the curtain reopens having hit the floor the safety edge exclusion should be set to 'turn off' the edge 50mm before it hits the floor. Please be aware the safety edge will have to return to the top limit before closing and the alarm will be disabled.



fig.14

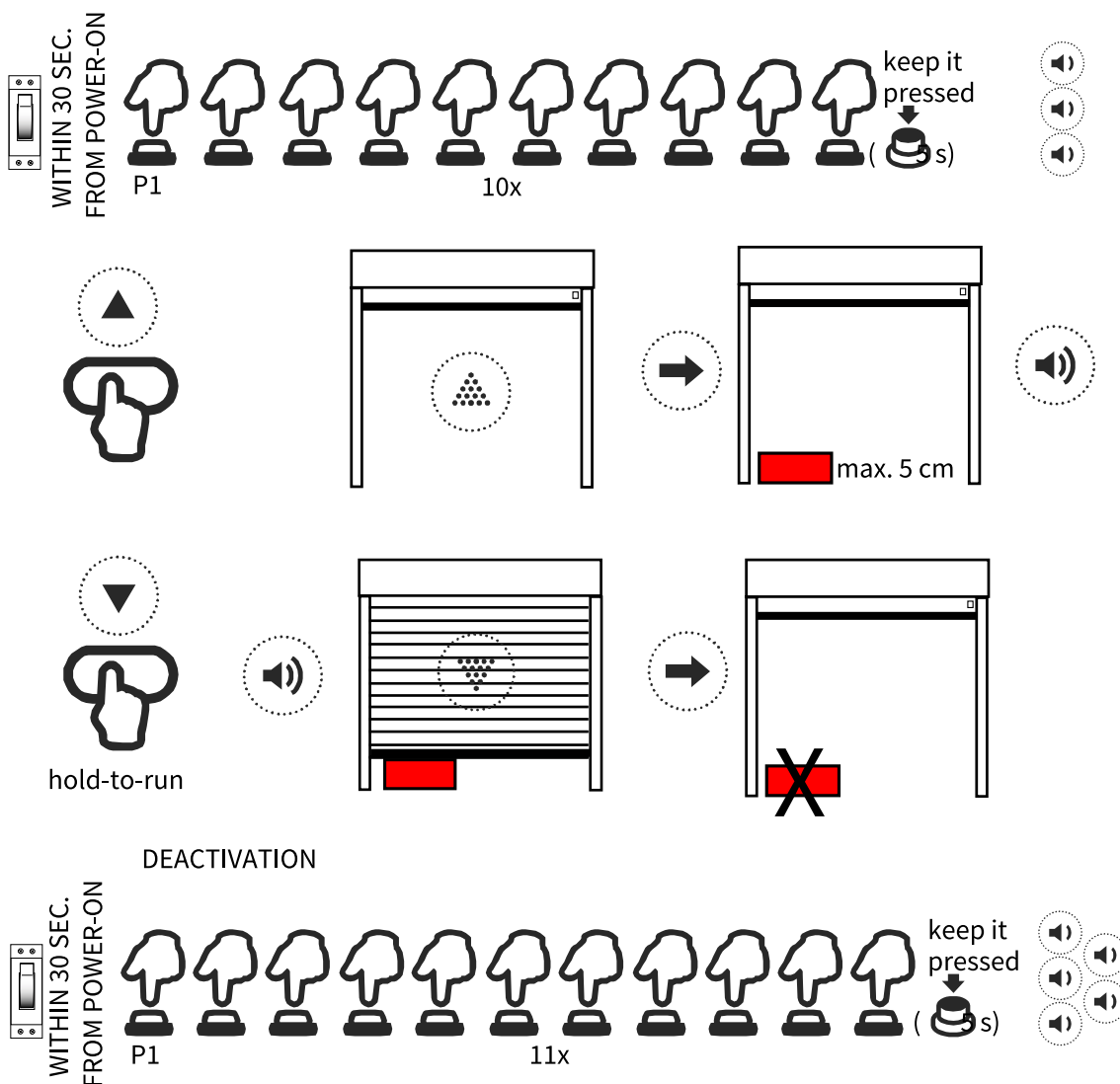



4. TROUBLESHOOTING

Acoustic signals from the control unit		
Sequence	Meaning	Solution
1 constant beep (continuous or intermittent)	Faulty control unit	Replace the control unit
2 beeps	Motor problem	<ul style="list-style-type: none">- Set the limit switches- The thermal protection could be activated. Wait while the motor cools down.- Check the motor connection- Test the motor separately by means of a proper tool
3 beeps at startup	Radio receiver is empty	Memorize at least one transmitter
4 beeps	Radio receiver is full	Max. number of transmitter exceeded
5 beeps (L1 = ON)	Safety test failure: wireless safety edge system	<ul style="list-style-type: none">- Check the rubber profile general condition- Check photocells alignment and the connections
6 beeps (L2 = ON)	Safety test failure: emergency STOP (TB)	Check the safety device connected and the connections
8 beeps	Limit switch error: the manoeuvre exceeded the working time.	Check the limit switches and, in case, set them again
9/10 beeps	One of the relay is defective (see par. 2.2)	Replace the control unit
Other possible issues		
Problem	Solution	
None of the previous signals, but the door doesn't move downward	Command an opening manoeuvre until the top limit has reached.	
In the closure, the door hits the floor and opens again	<ul style="list-style-type: none">- The bottom limit could be too low, adjust it upwards- In case of uneven floor use the procedure 3.3 to deactivate the safety edge in the last part of the closure. It is necessary to command the closure starting from the upper limit switch in order to be effective.	
The door can be operated but the safety systems don't activate	Check the motor direction. If wrong, swap brown and black motor wires over (terminals 5 & 7)	
The control units responds to the commands sent by transmitters, but the front cover is not functioning	If L5 led flashes, the "holiday mode" is activated	
The fuse blows while operating the door	Check again the wirings	
WARNING: in case that the safety devices (except for TB input) are defective or they have been activated, it is possible to operate the door anyway, keeping pressed the command button for more than 5 seconds. The control unit will automatically switch to hold-to-run mode.		

Rollerdor Ltd
10 & 12 Jarrold Way
Bowthorpe Employment Area
Norwich
Norfolk NR5 9JD

+44 (0)1603 743215
sales@rollerdor.net
www.rollerdor.net

Company Registration Number. 10676267

Registered Office Address:
Rollerdor Ltd, Bankside 300 Peachman Way,
Broadland Business Park, Norwich,
Norfolk, United Kingdom, NR7 0LB

Edition 2024/1

